

LM161/LM361 High Speed Differential Comparators

General Description

The LM161/LM361 is a very high speed differential input, complementary TTL output voltage comparator with improved characteristics over the SE529/NE529 for which it is a pin-for-pin replacement. The device has been optimized for greater speed performance and lower input offset voltage. Typically delay varies only 3 ns for over-drive variations of 5 mV to 500 mV. It may be operated from op amp supplies ($\pm 15V$).

Complementary outputs having maximum skew are provided. Applications involve high speed analog to digital converters and zero-crossing detectors in disk file systems.

Features

- Independent strobes
- Guaranteed high speed: 20 ns max
- Tight delay matching on both outputs
- Complementary TTL outputs
- Operates from op amp supplies: $\pm 15V$
- Low speed variation with overdrive variation
- Low input offset voltage
- Versatile supply voltage range

Connection Diagrams

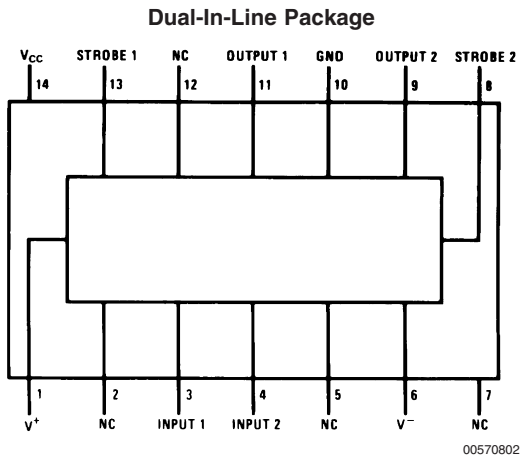

Top View

Order Number LM361M, LM361MX or LM361N
See NS Package Number M14A or N14A

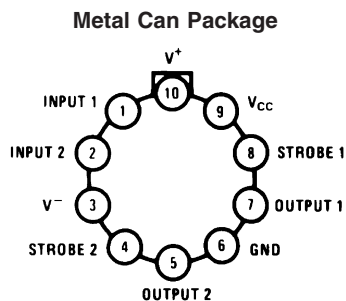

Order Number LM161H/883 or LM361H
See NS Package Number H10C

Logic Diagram

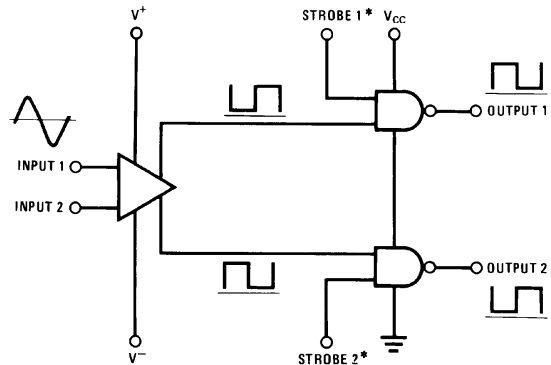

*Output is low when current is drawn from strobe pin.

00570804

Absolute Maximum Ratings (Note 1)

If Military/Aerospace specified devices are required, please contact the National Semiconductor Sales Office/Distributors for availability and specifications.

Positive Supply Voltage, V^+	+16V
Negative Supply Voltage, V^-	-16V
Gate Supply Voltage, V_{CC}	+7V
Output Voltage	+7V
Differential Input Voltage	$\pm 5V$
Input Common Mode Voltage	$\pm 6V$
Power Dissipation	600 mW
Storage Temperature Range	-65°C to +150°C
Operating Temperature Range	T_{MIN} T_{MAX}
LM161	-55°C to +125°C
	-25°C to +85°C
LM361	0°C to +70°C
Lead Temp. (Soldering, 10 seconds)	260°C
For Any Device Lead Below V^-	0.3V

	Min	Typ	Max
LM361	5V		15V
Supply Voltage V^-			
LM161	-6V		-15V
LM361	-6V		-15V
Supply Voltage V_{CC}			
LM161	4.5V	5V	5.5V
LM361	4.75V	5V	5.25V
ESD Tolerance (Note 5)			1600V
Soldering Information			
Dual-In-Line Package			
Soldering (10 seconds)			260°C
Small Outline Package			
Vapor Phase (60 seconds)			215°C
Infrared (15 seconds)			220°C

See AN-450 "Surface Mounting Methods and Their Effect on Product Reliability" for other methods of soldering surface mount devices.

Operating Conditions

	Min	Typ	Max
Supply Voltage V^+			
LM161	5V		15V

Electrical Characteristics

($V^+ = +10V$, $V_{CC} = +5V$, $V^- = -10V$, $T_{MIN} \leq T_A \leq T_{MAX}$, unless noted)

Parameter	Conditions	Limits						Units
		LM161			LM361			
		Min	Typ	Max	Min	Typ	Max	
Input Offset Voltage			1	3		1	5	mV
Input Bias Current	$T_A=25^\circ C$		5	20		10	30	μA
Input Offset Current	$T_A=25^\circ C$		2	3		2	5	μA
Voltage Gain	$T_A=25^\circ C$		3			3		V/mV
Input Resistance	$T_A=25^\circ C$, $f=1$ kHz		20			20		k Ω
Logical "1" Output Voltage	$V_{CC}=4.75V$, $I_{SOURCE}=-0.5$ mA	2.4	3.3		2.4	3.3		V
Logical "0" Output Voltage	$V_{CC}=4.75V$, $I_{SINK}=6.4$ mA			0.4			0.4	V
Strobe Input "1" Current (Output Enabled)	$V_{CC}=5.25V$, $V_{STROBE}=2.4V$			200			200	μA
Strobe Input "0" Current (Output Disabled)	$V_{CC}=5.25V$, $V_{STROBE}=0.4V$			-1.6			-1.6	mA
Strobe Input "0" Voltage	$V_{CC}=4.75V$			0.8			0.8	V
Strobe Input "1" Voltage	$V_{CC}=4.75V$	2			2			V
Output Short Circuit Current	$V_{CC}=5.25V$, $V_{OUT}=0V$	-18		-55	-18		-55	mA
Supply Current I^+	$V^+=10V$, $V^-=-10V$, $V_{CC}=5.25V$, $-55^\circ C \leq T_A \leq 125^\circ C$			4.5				mA

Electrical Characteristics (Continued)(V⁺ = +10V, V_{CC} = +5V, V⁻ = -10V, T_{MIN} ≤ T_A ≤ T_{MAX}, unless noted)

Parameter	Conditions	Limits						Units
		LM161			LM361			
		Min	Typ	Max	Min	Typ	Max	
Supply Current I ⁺	V ⁺ =10V, V ⁻ =-10V, V _{CC} =5.25V, 0°C≤T _A ≤70°C						5	mA
Supply Current I ⁻	V ⁺ =10V, V ⁻ =-10V, V _{CC} =5.25V, -55°C≤T _A ≤125°C			10				mA
Supply Current I ⁻	V ⁺ =10V, V ⁻ =-10V, V _{CC} =5.25V, 0°C≤T _A ≤70°C						10	mA
Supply Current I _{CC}	V ⁺ =10V, V ⁻ =-10V, V _{CC} =5.25V, -55°C≤T _A ≤125°C			18				mA
Supply Current I _{CC}	V ⁺ =10V, V ⁻ =-10V, V _{CC} =5.25V, 0°C≤T _A ≤70°C						20	mA
Transient Response	V _{IN} = 50 mV overdrive (Note 3)							
Propagation Delay Time (t _{pd(0)})	T _A =25°C		14	20		14	20	ns
Propagation Delay Time (t _{pd(1)})	T _A =25°C		14	20		14	20	ns
Delay Between Output A and B	T _A =25°C		2	5		2	5	ns
Strobe Delay Time (t _{pd(0)})	T _A =25°C		8			8		ns
Strobe Delay Time (t _{pd(1)})	T _A =25°C		8			8		ns

Note 1: The device may be damaged by use beyond the maximum ratings.**Note 2:** Typical thermal impedances are as follows:

	<u>H Package</u>	<u>J Package</u>	<u>N Package</u>
θ _{JA}	165°C/W (Still Air) 67°C/W (400 LF/Min Air Flow)	112°C/W	105°C/W
θ _{JC}	25°C/W		

00570817

Note 3: Measurements using AC Test circuit, Fanout = 1. The devices are faster at low supply voltages.**Note 4:** Refer to RETS161X for LM161H and LM161J military specifications.**Note 5:** Human body model, 1.5 kΩ in series with 100 pF.

Typical Performance Characteristics

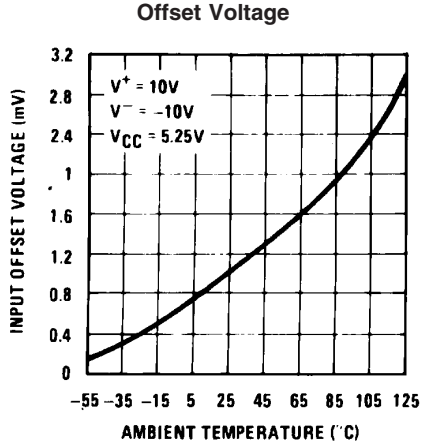

00570808

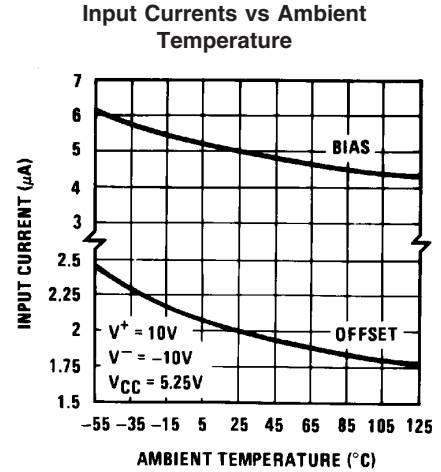

00570809

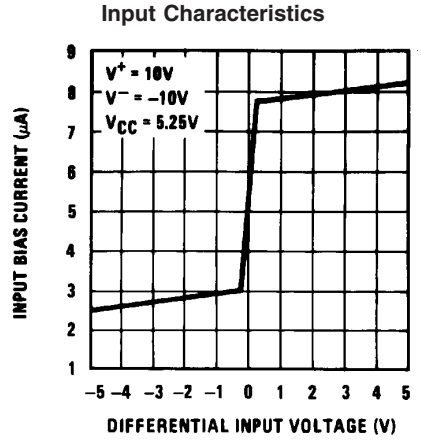

00570810

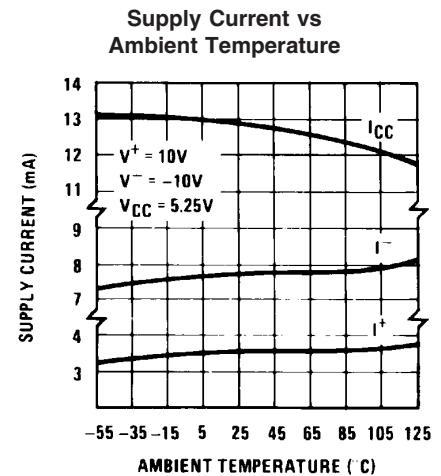

00570811

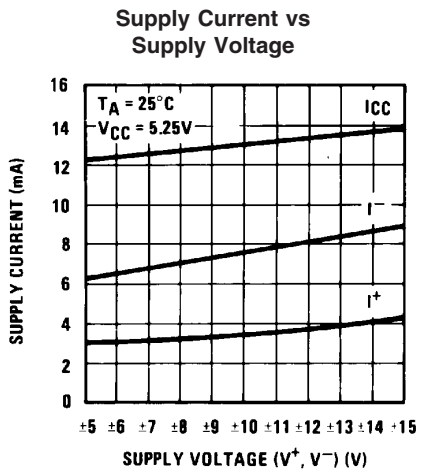

00570812

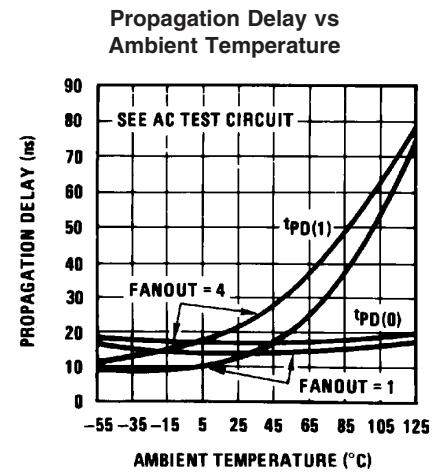

00570813

Typical Performance Characteristics (Continued)

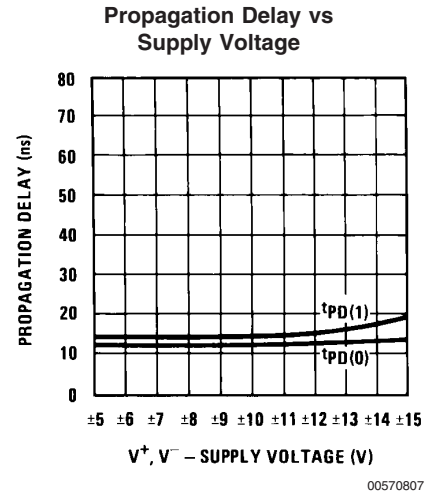
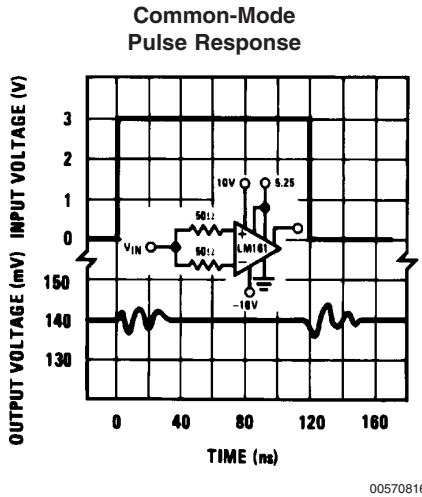
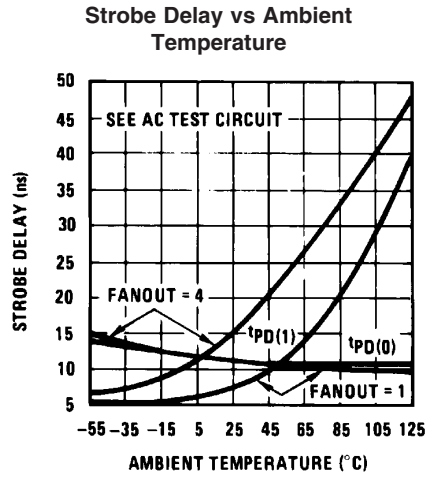
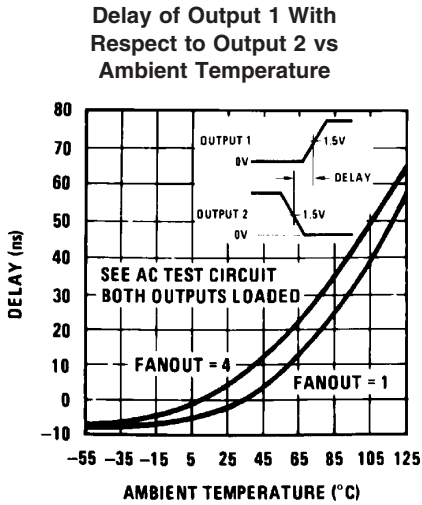

AC Test Circuit

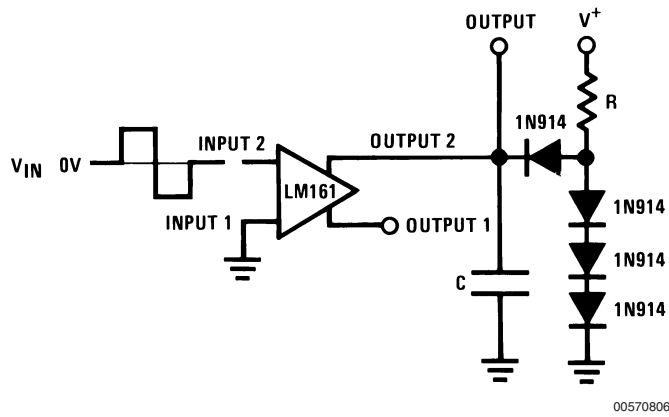

$V_{IN} = \pm 50 \text{ mV}$	FANOUT = 1	FANOUT = 4	$V^- = -10\text{V}$	$C = 15 \text{ pF}$	$C = 30 \text{ pF}$
$V^+ = +10\text{V}$	$R = 2.4\text{k}$	$R = 680\Omega$	$V_{CC} = 5.25\text{V}$		

Schematic Diagram

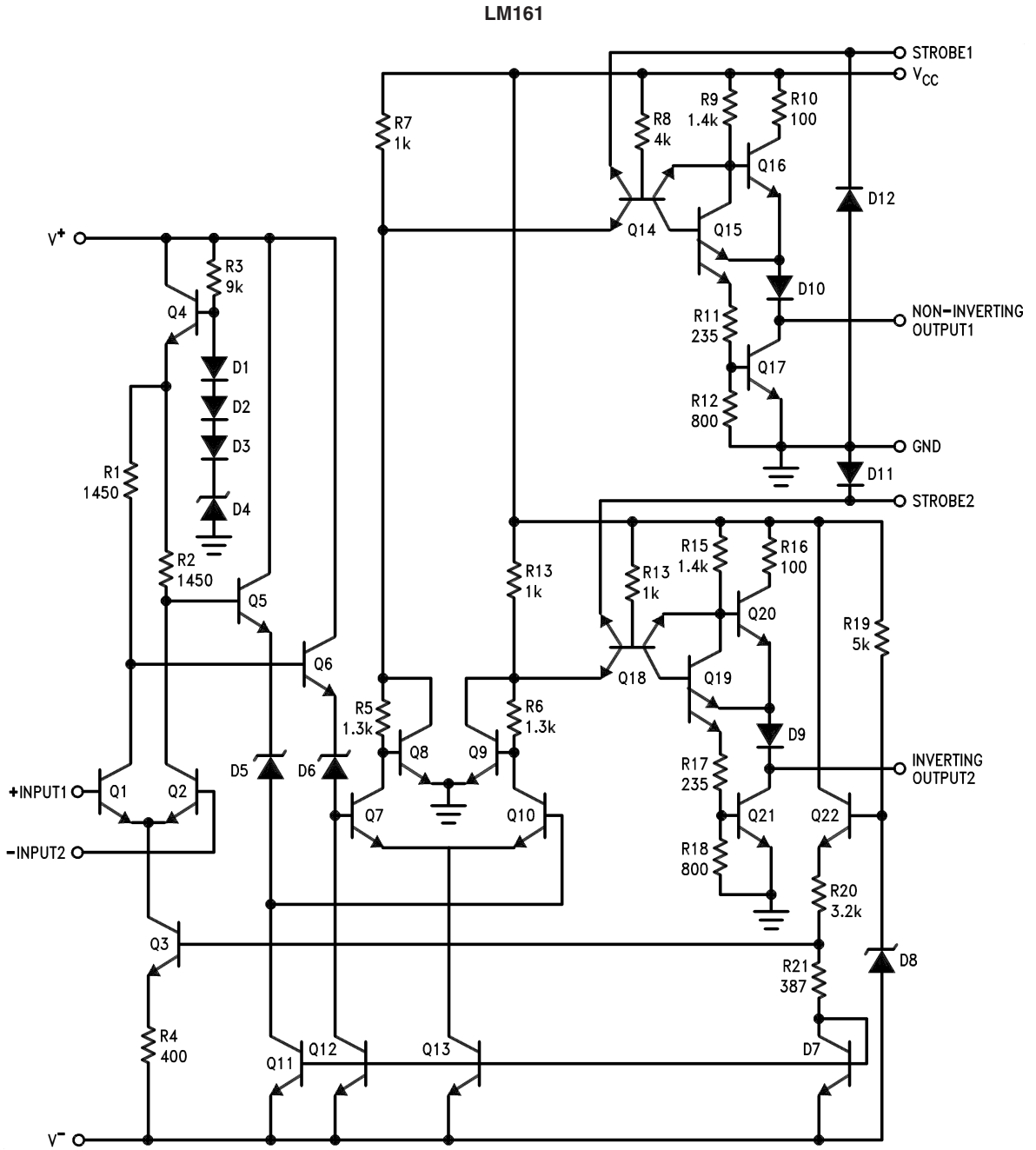

R10, R16: 85
 R11, R17: 205

00570801

Physical Dimensions inches (millimeters)

unless otherwise noted

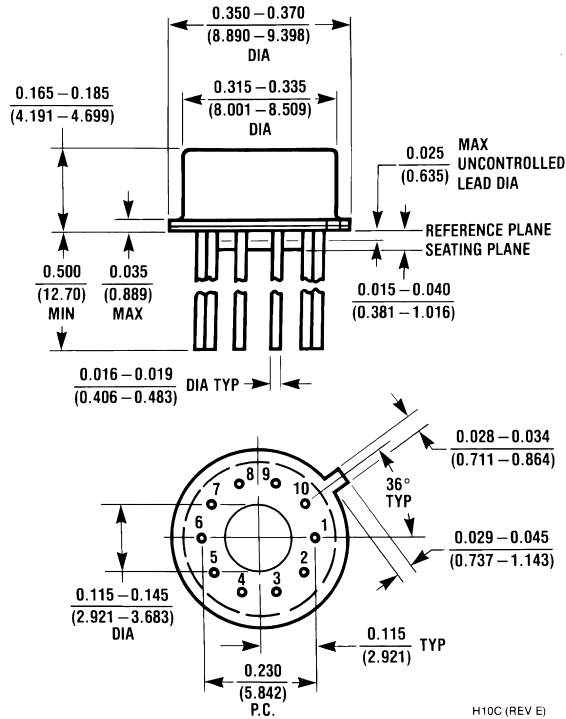

Metal Can Package (H)
Order Number LM161H/883, or LM361H
NS Package Number H10C

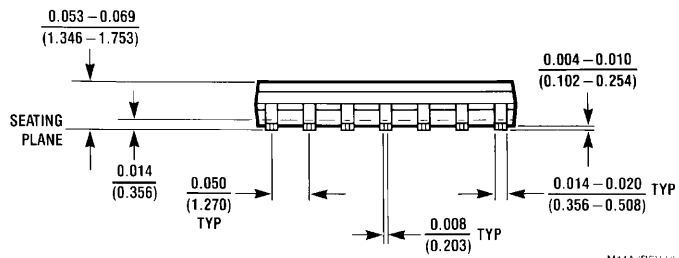
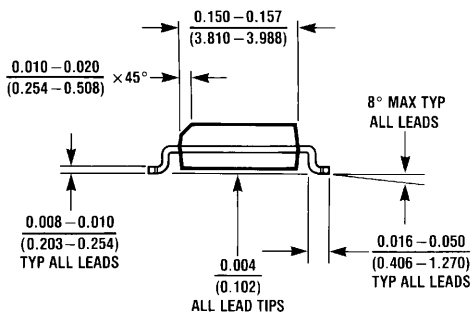
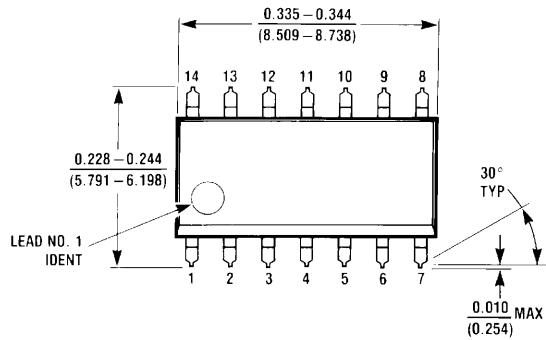

Order Number LM361M or LM361MX
NS Package Number M14A

Physical Dimensions inches (millimeters) unless otherwise noted (Continued)

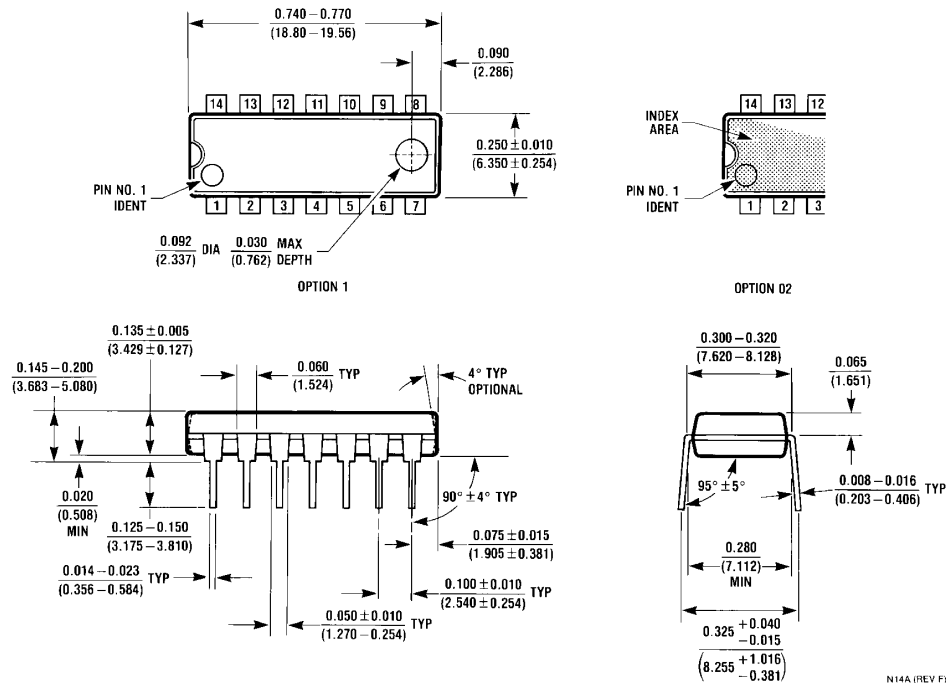

**Molded Dual-In-Line Package (N)
Order Number LM361N
NS Package Number N14A**

National does not assume any responsibility for use of any circuitry described, no circuit patent licenses are implied and National reserves the right at any time without notice to change said circuitry and specifications.

For the most current product information visit us at www.national.com.

LIFE SUPPORT POLICY

NATIONAL'S PRODUCTS ARE NOT AUTHORIZED FOR USE AS CRITICAL COMPONENTS IN LIFE SUPPORT DEVICES OR SYSTEMS WITHOUT THE EXPRESS WRITTEN APPROVAL OF THE PRESIDENT AND GENERAL COUNSEL OF NATIONAL SEMICONDUCTOR CORPORATION. As used herein:

1. Life support devices or systems are devices or systems which, (a) are intended for surgical implant into the body, or (b) support or sustain life, and whose failure to perform when properly used in accordance with instructions for use provided in the labeling, can be reasonably expected to result in a significant injury to the user.
2. A critical component is any component of a life support device or system whose failure to perform can be reasonably expected to cause the failure of the life support device or system, or to affect its safety or effectiveness.

BANNED SUBSTANCE COMPLIANCE

National Semiconductor certifies that the products and packing materials meet the provisions of the Customer Products Stewardship Specification (CSP-9-111C2) and the Banned Substances and Materials of Interest Specification (CSP-9-111S2) and contain no "Banned Substances" as defined in CSP-9-111S2.

 **National Semiconductor**
Americas Customer
Support Center
Email: new.feedback@nsc.com
Tel: 1-800-272-9959

National Semiconductor
Europe Customer Support Center
Fax: +49 (0) 180-530 85 86
Email: europe.support@nsc.com
Deutsch Tel: +49 (0) 69 9508 6208
English Tel: +44 (0) 870 24 0 2171
Français Tel: +33 (0) 1 41 91 8790

National Semiconductor
Asia Pacific Customer
Support Center
Email: ap.support@nsc.com

National Semiconductor
Japan Customer Support Center
Fax: 81-3-5639-7507
Email: jpn.feedback@nsc.com
Tel: 81-3-5639-7560